

**Making Your Job More Enjoyable**

**Vacuum Pump Operating Manual  
R32 Series Pump**



Since the start of our operation, VALUE takes pride in producing reliable & high quality vacuum pumps. VALUE regards customer value as its core conception and undertakes customer requirements as its research basis. With the constant pursuit of excellent quality and high reliability products, VALUE is proud to launch high reliability iPump series, which caters to global customers' needs.

VALUE's new iPump series design is a delicate engineering process. In the beginning, our research team has distributed over 1,200 copies of survey in determining our product position in the market, we also communicate with customers from more than 30 countries and regions. Analyze the strength of previous VE series, retain the popular parts and analyze the parts to be improved of new series. Our design team launches this program finally after conclusion.

It takes us more than 6 months from conception to finalization. In the initial phase of development, we engaged the services of following experts. There are ABB electrical expert, VALEO quality assurance & manufacturing expert, Shell lubricants manufacturing expert, vacuum technology expert, and industrial design expert. With their combine expertise, the development of the product has finally come to fruition.

We import Japanese OKUMA vertical machining center, German WENZEL 3D measuring machine in order to ensure VALUE iPump series' design quality. VALUE applies lean production management to guarantee the precision of the products from process, measurement and assembly.

iPump series most advantageous point is its high reliability. The entire structure is highly durable, achieving a standard of 0.008; Big sight glass, low oil level, built-in oil pump cycling system and SHELL high quality vacuum oil forced-lubricates the pump chamber; Imported oil seal guarantee the pump's reliable sealing and long life span under any working condition. In addition, VALUE use Switzerland SANVIK exhaust valve which can assure life span usage of 10 billion times. All these will guarantee VALUE iPump series vacuum pump's high quality and reliability.

# CONTENT

I Safety precaution.....	1
II Description.....	1
III Pump components.....	3
1. Operating.....	4
1.1 Before operating.....	4
1.2 To shut off the pump after use.....	5
2. Maintenance.....	5
2.1 Vacuum pump oil.....	5
2.2 Oil change procedure.....	5
3. Technical drawing.....	7
4. Technical parameter.....	9
5. Trouble shooting.....	11
6. Limited warranty statements.....	12

## I Safety precaution

**To prevent personal injury, please read the operating manual carefully**

1. Wear goggles when working with refrigerants. Contact with refrigerants may cause injury.
2. Confirm all associated devices are grounded correctly before energizing circuit to avoid electrical shock hazards.
3. Normal operating temperature will cause certain portions of the pump to be hot to touch. Do not touch the pump housing or motor during operation.

## II Description

VALUE vacuum pumps are widely used in the refrigeration service including CFC, HCFC, and HFC refrigerants, printing industry, vacuum packaging, gas analysis, thermo forming industry and so on. It can also be applicable as the pre-pump of various types of high vacuum equipment.

You will appreciate these key features:

1. High vacuum, high pump speed

Two stage rotary-vane design improves the ultimate vacuum and pump speed and reduces the evacuation time.

2. Integrated pump body design

Integrated pump body design ensures the reliability and easy maintenance.

3. Oil pump cycling system design

Built-in oil pump cycling design forced-lubricates the pump chamber and sliding bearing and ensures its lubrication and seal. Besides, big sight glass and low oil level design avoids running without oil and ensures reliable usage.

#### 4. Anti-suckback design

Anti-suckback design prevents oil from returning to the system and keeping the purity of the system.

#### 5. Gas ballast design

Gas ballast design prevents moisture condensation and keeping the purity of the pump oil.

#### 6. Lifetime Filtration

The intake filter can prevent foreign matter from entering into the pump chamber, and the exhaust fitting separates oil vapor from the exhaust flow.

#### 7. Solid and comfortable handle

Special metal handle makes it easy to carry the pump and guarantee the pump's reliable use during operation. High quality rubber handle slipcover can always maintain its room temperature.

#### 8. Good material

Aluminum oil housing, trestle and motor cover makes the pump light, metal base ensures the reliability of the pump.

#### 9. Thermal protector

Thermal protector in the motor makes the pump run steadily and safety.

### III Pump components

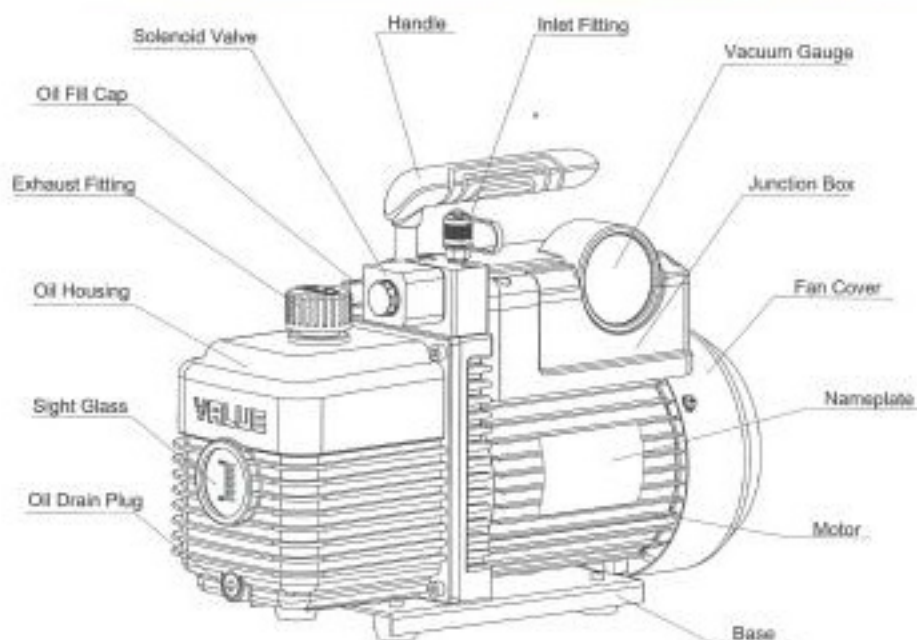

**Remark: Only new refrigerant series are assembled with solenoid valve and vacuum gauge**

## 1. Operating

### 1.1 Before operating

All motors are designed for operating voltages plus or minus 10% of the normal rating. Single Voltage motors are supplied fully connected and ready to operate.

- (a) Check the voltage and frequency at the outlet and ensure it matches the specifications on the pump motor nameplate. Ensure that the ON-OFF switch is in the OFF position before connecting the pump to a power source.
- (b) Fill the oil reservoir with oil before activate the pump. Remove the Oil Fill Cap and add oil until oil level show in the middle between the Min and Max mark.



Refer to technical data in manual for the correct oil capacity of pump.

**Attention: Filling speed can't be so fast in case of oil spillage.**

- (c) Place back the Oil Fill cap. Turn the motor switch to ON position. Place back the cap on the inlet fitting when the pump runs smoothly. This may takes 2 to 30 seconds depend on the ambient temperature. After the pump operates for approximately one minute, check the sight glass for proper oil level, which should always be visible in the middle between Max and Min mark. Refill oil if necessary.

**Note: The oil level should always be visible in the middle between Max and Min mark when the pump is running. Insufficient oil filled will result in poor vacuum performance. Excessive of oil can result in overflowing of oil from the exhaust fitting.**

- (d) Oil mist will come out during operation. Special oil mist filter is needed if environment can't permit.

## 1.2 To shut off pump after use

To prolong pump life span and smooth start-up, these procedures to shut off pump should be followed.

- (a) Turn off the manifold valve between the pump and the system.
- (b) Remove the hose from the pump inlet.
- (c) Cover the inlet port openings to prevent any contamination or foreign particles from entering the port.

## 2. Maintenance

### 2.1 Vacuum pump oil:

The condition and type of oil used in any high performance vacuum pump are extremely important in determining the ultimate attainable vacuum. It is recommended to use the High Performance Vacuum Pump Oil, which is specifically blended to maintain maximum viscosity at normal running temperatures and to improve cold weather start up.

### 2.2 Oil Change Procedure

- (a) Ensure the pump is warmed up.
- (b) Remove the Oil Drain cap. Drain off contaminated oil into a container and dispose it properly. Oil can be removed from the pump by opening the inlet and partially blocking the exhaust with a cloth while the pump is running. Do not operate the pump for more than 20 seconds using this method.
- (c) When the drainage of oil completed, tilt the pump forward to remove the residual oil.
- (d) Place back the Oil Drain Cap. Remove the Oil Fill Cap and fill the oil reservoir with new vacuum pump oil until oil level is seen in the middle between Max and Min mark.



- (e) Ensure that the inlet ports are covered before turn on the pump. Allow it to run for one minute to check the oil level. If the oil level is below the sight glass Min level, fill oil slowly (with the pump running) until the oil level show in the middle between Max and Min mark. Place back the Oil Fill cap, ensure the inlet is covered and the oil drain cap is closed tightly.
- (f) 1) If the oil is badly contaminated with sludge that forms during operation, you may need to remove the oil reservoir cover and wipe it.
- 2) The alternative method to deal with heavily contaminated oil is to force the oil from the pump reservoir. Leave the pump to run until it is warmed up. While the pump is still running, remove the oil drain cap and restrict the exhaust slightly. This will back-pressure the oil reservoir and purge the oil with contaminants. Turn off the pump when oil stops flowing.
- 3) Repeat this procedure as required until the contaminants is removed completely.
- 4) Replace the Oil Drain cap and refill the oil reservoir to the proper oil level with clean vacuum pump oil.

### 3. Technical Drawing

Suit for V-i220-R32, V-i240-R32

V-i120-R32, V-i125-R32,

V-i140-R32, V-i160-R32

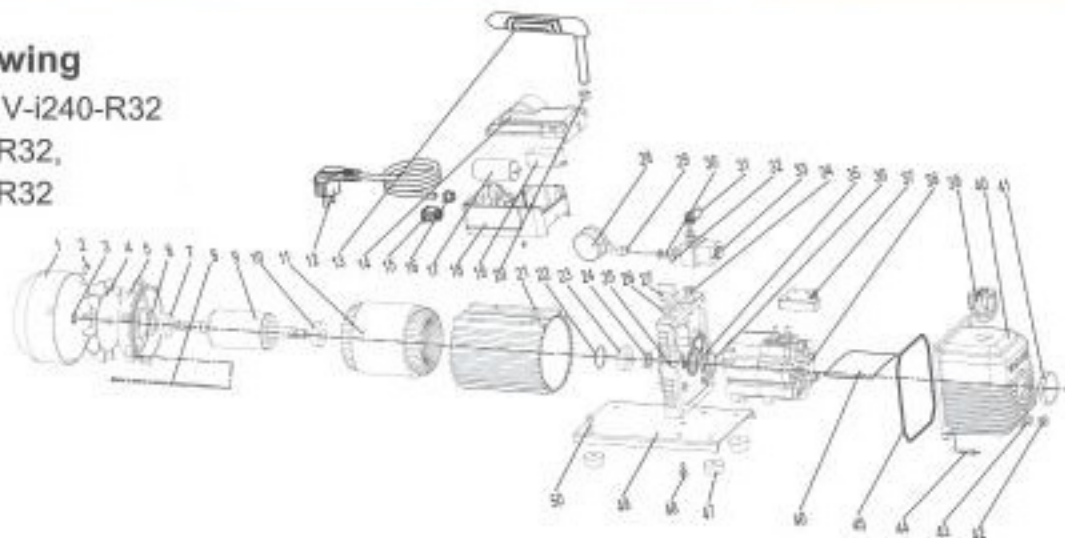

1	Fan cover	14	Power switch	27	Oil fill cap	40	Oil housing assembly
2	Cross screw	15	Insulating bushing	28	Vacuum gauge	41	Sight glass
3	Elastic collar	16	Electronic starter	29	Connecting pipe assembly	42	Oil drain plug
4	Fan	17	Junction box	30	O ring	43	O ring
5	Motor cover	18	Nut	31	Inlet cap	44	Cross screw
6	Bearing	19	Capacitor	32	Pressure plate	45	O ring
7	Cross screw	20	Capacitor	33	Solenoid Valve	46	Oil baffle
8	Motor rotor	21	Motor hull	34	Filter	47	Rubber feet
9	Bearing	22	Waveform gasket	35	O ring	48	Cross screw
10	Motor stator	23	Bearing	36	O ring	49	Base
11	Power supply cord	24	Oil seal	37	Oil shield	50	Cross screw
12	Handle	25	Trestle	38	Pump body		
13	Junction box cover	26	O ring	39	Filtrate assembly		

### 3. Technical Drawing

Suit for V-i260-R32, V-i280-R32, V-i180-R32

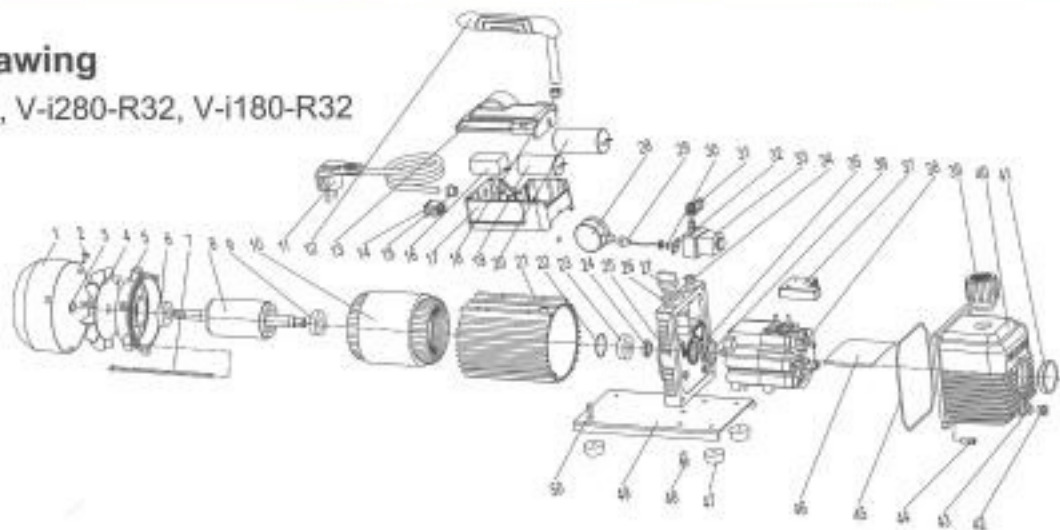

1	Fan cover	14	Junction box cover	27	Oil fill cap	40	Oil housing assembly
2	Cross screw	15	Power switch	28	Vacuum gauge	41	Sight glass
3	Elastic collar	16	Insulating bushing	29	Connecting pipe assembly	42	Oil drain plug
4	Fan	17	Capacitor	30	O ring	43	O ring
5	Motor cover	18	Junction box	31	Inlet cap	44	Cross screw
6	Waveform gasket	19	Electronic starter	32	Pressure plate	45	O ring
7	Bearing	20	Nut	33	Solenoid Valve	46	Oil baffle
8	Cross screw	21	Motor hull	34	Filter	47	Rubber feet
9	Motor rotor	22	Bearing gasket	35	O ring	48	Cross screw
10	Bearing	23	Bearing	36	O ring	49	Base
11	Motor stator	24	Oil seal	37	Oil shield	50	Cross screw
12	Power supply cord	25	Trestle	38	Pump body		
13	Handle	26	O ring	39	Filtrate assembly		

## 4. Technical paramete

Model		V-i220-R32		V-i240-R32		V-i260-R32		V-i280-R32	
Flow Rate	50Hz	1.8 CFM	51L/min	3.5 CFM	100L/min	5.0 CFM	142L/min	7.0 CFM	198L/min
	60Hz	2.0 CFM	57L/min	4 CFM	113L/min	6.0 CFM	170L/min	8.0 CFM	226L/min
Ultimate Vacuum		15 micron		15 micron		15 micron		15 micron	
Power		1/3 HP		1/2 HP		3/4 HP		1 HP	
Inlet Port		1/4" SAE		1/4" SAE		1/4" SAE		1/4" SAE	
Oil Capacity		200ml		325ml		580ml		500ml	
Dimensions		318x124x237 mm		338x138x249 mm		395x145x262 mm		395x145x262 mm	
Weight		9.0 Kg		11.0 Kg		16.6 Kg		17.0 Kg	

Model		V-i120-R32		V-i125-R32		V-i140-R32		V-i160-R32		V-i180-R32	
Flow Rate	50Hz	1.8 CFM	51L/min	2.5 CFM	70 L/min	3.5 CFM	100L/min	5.0 CFM	142L/min	7.0 CFM	198L/min
	60Hz	2.0 CFM	57L/min	3.0 CFM	84 L/min	4 CFM	113L/min	6.0 CFM	170L/min	8.0 CFM	226L/min
Ultimate Vacuum		150 micron		150 micron		150 micron		150 micron		150 micron	
Power		1/4 HP		1/4 HP		1/3 HP		1/2 HP		3/4 HP	
Inlet Port		1/4" SAE		1/4" SAE		1/4" SAE		1/4" SAE		1/4" SAE	
Oil Capacity		250ml		250ml		250ml		415 ml		660 ml	
Dimensions		290x124x223 mm		290x124x223 mm		318x124x237 mm		338x138x249 mm		395x145x262 mm	
Weight		6.7 kg		7.2 kg		8.6 kg		10.3 kg		15.4 kg	

**Note: 1.This product operates in ambient temperature: 5℃~40℃**

**2.Power supply of the products are 220-240V/50-60Hz**

**Warning :** If the ambient temperature is too hot or the voltage is too high, the product may stop functioning. It is recommended not to switch off the power supply immediately. If the product re-startup automatically after 3 minutes, it is recommended to cool the product by lowering the ambient temperature or power supply voltage to prolong the life span of the vacuum pump.

## 5. Trouble shooting

Fault	Possible cause	Remedy	Remark
<b>Failure to attain a good vacuum</b>	<ol style="list-style-type: none"> <li>1. The spare intake port cap loosen</li> <li>2. O-Ring inside the spare intake port cap damage.</li> <li>3. Insufficient oil</li> <li>4. Pump oil emulsification or dirty</li> <li>5. Oil inlet channel is clogged or insufficient oil</li> <li>6. Pumping system leak</li> <li>7. Not suitable pump</li> <li>8. Pump spare parts are worn out after long use</li> </ol>	<ol style="list-style-type: none"> <li>1. Fasten the intake port cap</li> <li>2. Change the O ring</li> <li>3. Add oil</li> <li>4. change oil</li> <li>5. Clean the oil inlet channel, clean the filter screen</li> <li>6. Check the pumping system, no leakage</li> <li>7. Chose the right pump</li> <li>8. Repair the pump or replace the pump if necessary.</li> </ol>	
<b>Oil leakage</b>	<ol style="list-style-type: none"> <li>1. Oil seal damage</li> <li>2. Oil housing assy connections loosen or damage.</li> </ol>	<ol style="list-style-type: none"> <li>1. Change oil seal</li> <li>2. Fasten the screw and change the O ring in the oil housing assy.</li> </ol>	
<b>Oil injection</b>	<ol style="list-style-type: none"> <li>1. Excessive oil in the pump</li> <li>2. Continuous operation under high pressure in the inlet port</li> </ol>	<ol style="list-style-type: none"> <li>1. Drain oil</li> <li>2. Chose the right pump</li> </ol>	
<b>Failure to start</b>	<ol style="list-style-type: none"> <li>1. Oil temperature is too low</li> <li>2. Malfunction of motor or power supply</li> <li>3. Foreign matters entered into the pump chamber</li> <li>4. The voltage is too low</li> <li>5. The power supply extended line is too long</li> </ol>	<ol style="list-style-type: none"> <li>1. Start the pump repeatedly while keep the pump oil free or heat the pump oil</li> <li>2. Check and repair</li> <li>3. Check and clean the pump</li> <li>4. Check the operating voltage</li> <li>5. Shorten the power supply extended line.</li> </ol>	

**Remark: If these procedures do not correct the problem, contact with your nearest VALUE distributor or send your pump to our service centre, we will do our best to help you.**

## 6. Limited warranty statement

Warranty period is one year from the purchase date due to the quality of the products itself.

The following restrictions apply:

1. The warranty applies to the product in normal usage situation only, as described in the operating manual. All warranty service claims must be made within the specified warranty period. Proof-of-purchase date must be supplied to the manufacturer.
2. Warranty service claims are subject to authorized inspection for product defects.
3. Warranty service applies to the product without un-authorized repairing or dis-assembling.

**Remark: The manufacturer shall not be responsible for any additional costs associated with a product failure, including loss of work time, loss of refrigerant, cross-contamination of refrigerant, and unauthorized shipping or labor charges.**



**VALUE Mechanical & Electrical Products CO., LTD**

Add: Jiulong Avenue, Western Industrial District, Wenzhou, Zhejiang, China

Tel: +86-576-86191959

Fax: +86-576-86191957

Email: [value@worldvalue.cn](mailto:value@worldvalue.cn)

[www.worldvalue.cn](http://www.worldvalue.cn)